

White LED Driver Constant Current Step-up Converter

Features and Benefits

- Output voltage up to 32 V (OVP level)
- 2.5 to 10 V input
- Drives up to 4 LEDs at 20 mA from a 2.5 V supply
- Drives up to 5 LEDs at 20 mA from a 3 V supply
- 1.2 MHz switching frequency
- 300 mA switch current limit
- 1 μ A shutdown current
- OVP pin eliminates the need for an external Zener diode on the output

Package: 6-pin MLP/DFN (suffix EH)

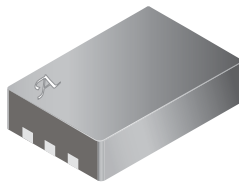

Approximate scale

Description

The A8431 is a noninverting boost DC-DC converter that provides a programmable constant-current output up to 32 V for driving white LEDs in series. The A8431 also offers an OVP (overvoltage protection) pin. Driving the LEDs in series ensures identical currents and uniform brightness. Up to four white LEDs can be driven at 20 mA from a single cell Li-ion or a multicell NiMH power source. Up to two parallel strings of eight white LEDs can be driven at 20 mA by increasing the supply voltage up to 10 V.

The A8431 incorporates a power switch and a feedback sense amplifier to provide a solution with minimum external components. The output current can be set by adjusting a single external sense resistor and can be varied with a voltage or a filtered PWM signal when dimming control is required. The high switching frequency of 1.2 MHz allows the use of small inductor and capacitor values.

The A8431 is provided in a 0.75 mm nominal height, 6-pin, 2 mm \times 3 mm MLP package. It is lead (Pb) free, with 100% matte tin leadframe plating.

Applications include:

- LED backlights
- Portable battery-powered equipment
- Cellular phones
- PDAs (Personal Digital Assistant)
- Camcorders, personal stereos, MP3 players, cameras
- Mobile GPS systems

Functional Block Diagram

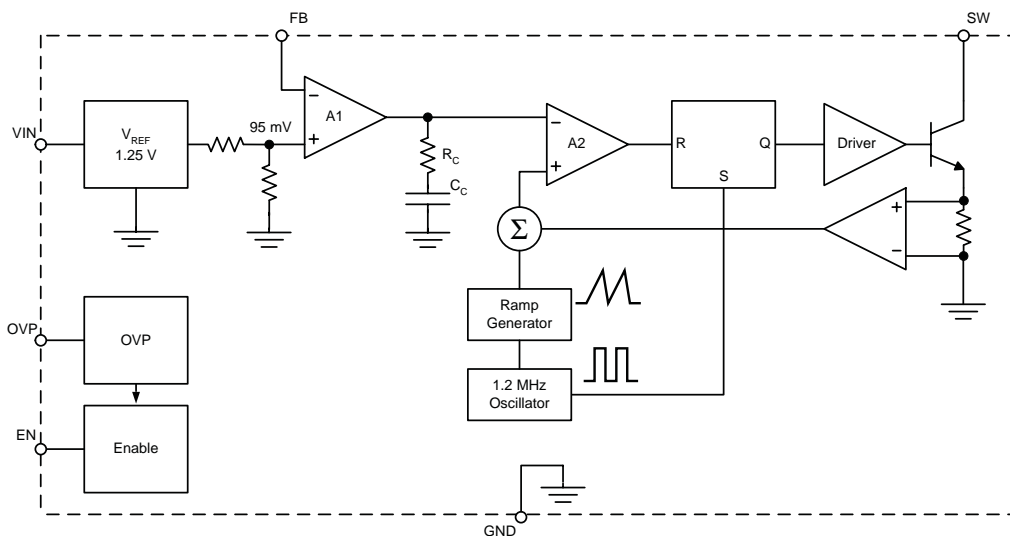

Selection Guide

Part Number	Packing*
A8431EEHTR-T	1500 pieces per 7-in. reel

*Contact Allegro for additional packing options



Absolute Maximum Ratings

Characteristic	Symbol	Notes	Rating	Units
SW Pin Voltage	V_{SW}		-0.3 to 36	V
OVP Pin Voltage	V_{OVP}		-0.3 to 36	V
Remaining Pin Voltage			-0.3 to 10	V
Operating Ambient Temperature	T_A	Range E	-40 to 85	°C
Maximum Junction Temperature	$T_J(\text{max})$		150	°C
Storage Temperature	T_{stg}		-55 to 150	°C

Pin-out Diagram

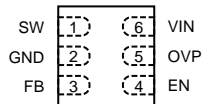

Terminal List Table

Pin	Name	Function
1	SW	Internal power FET
2	GND	Ground
3	FB	Feedback input
4	EN	Enable input
5	OVP	Overvoltage protection
6	VIN	Input supply

$R_{\theta JA} = 50 \text{ }^\circ\text{C/W}$, measured with 4-layer PCB. Please refer to application note “Package Thermal Characteristics,” for thermal performance measurement for 2 x 3 mm MLP package for additional information.

ELECTRICAL CHARACTERISTICS at $T_A = 25^\circ\text{C}$, $V_{IN} = 3\text{ V}$ (unless otherwise noted)

Characteristics	Symbol	Test Conditions	Min.	Typ.	Max.	Units
Input Voltage Range	V_{IN}		2.5	–	10	V
Supply Current	I_{SUP}	Active	–	2.5	3.5	mA
		Shutdown (EN=0V)	–	0.1	1	μA
Feedback Reference Voltage	V_{FB}		86	95	104	mV
Feedback Input Current	I_{FB}		–	20	75	nA
Switch Current Limit	I_{SWLIM}		–	300	–	mA
Switch Frequency	F_{SW}		0.8	1.2	1.6	MHz
Switch Maximum Duty Cycle	D		85	90	–	%
Switch Saturation Voltage	$V_{CE(SAT)}$		–	350	–	mV
Switch Leakage Current	I_{SL}	$V_{SW} = 5\text{ V}$	–	–	5	μA
Enable Input						
Input Threshold Low	V_{IL}		–	–	0.4	V
Input Threshold High	V_{IH}		1.5	–	–	V
Input Leakage	Leakage	I_{IL}	–	–	1	μA
Overvoltage Protection						
Output Overvoltage Rising Limit	V_{OVPR}		28	32	35	V
Output Overvoltage Falling Limit	V_{OVPF}		27.5	31.5	34.5	V
Output Overvoltage Hysteresis	V_{OVPHYS}		–	0.5	–	V
OVP Pin Resistance	R_{OVP}		–	1.0	–	$\text{M}\Omega$

Operating Characteristics

Using Typical Application Circuit (Schematic 1)

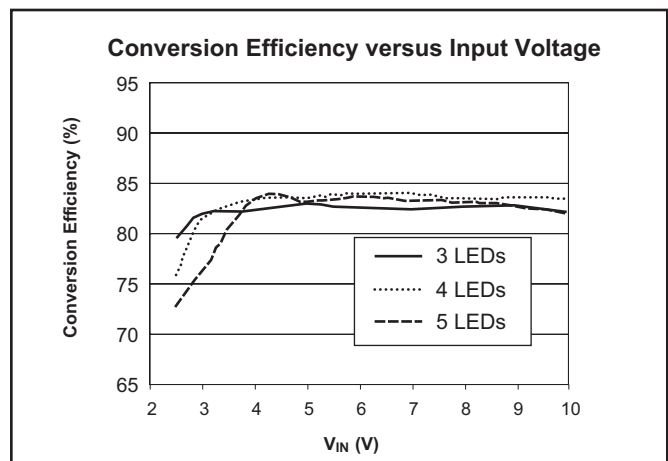
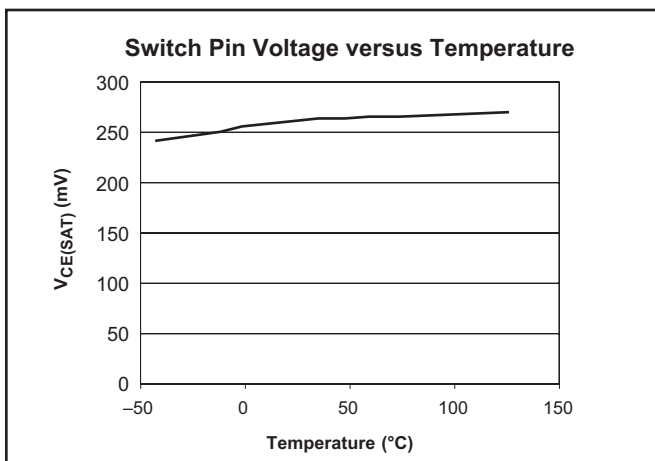
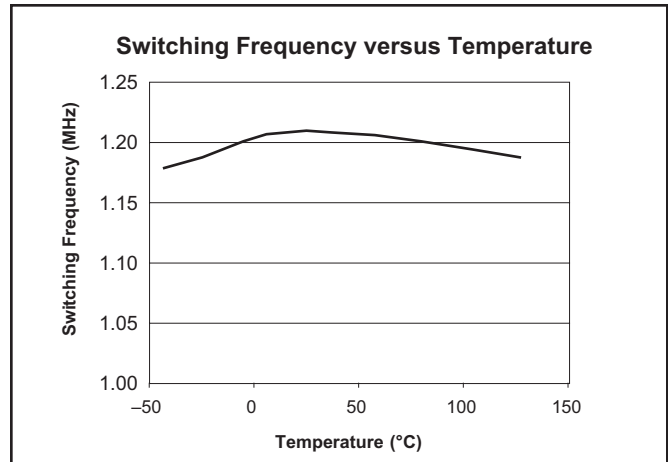
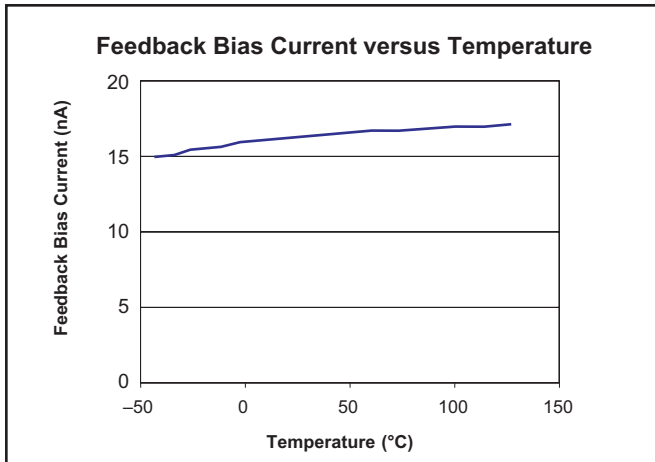
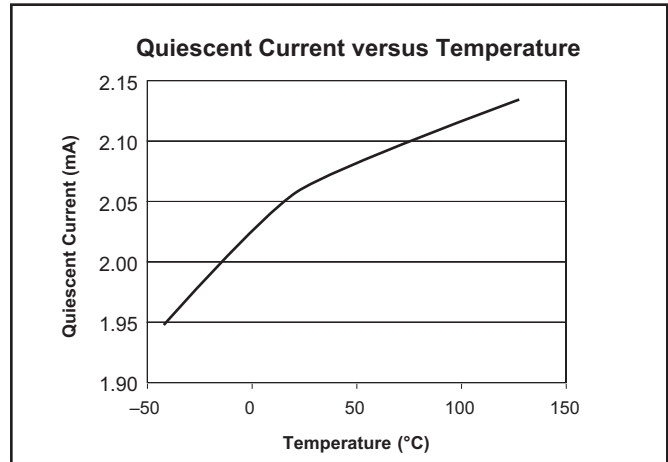
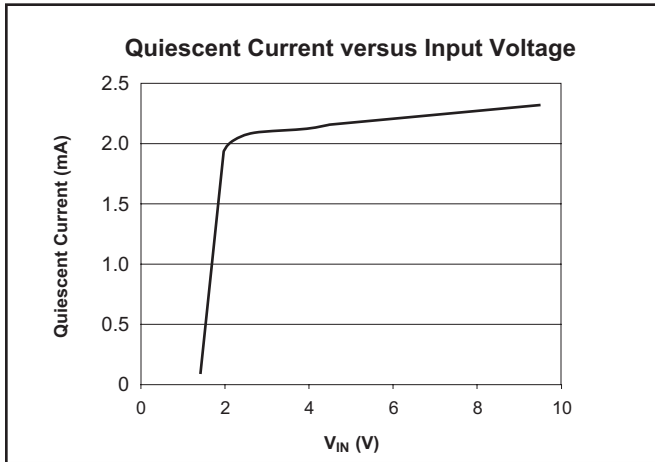

Functional Description

Typical Application

A typical application circuit for the A8431 is provided in schematic diagram 1. This illustrates a method of driving three white LEDs in series. The conversion efficiency of this configuration is shown in chart 1.

Pin Functions

The diagram also shows a method of connecting the individual pins, whose functions are described as follows:

VIN. Supply to the control circuit. A bypass capacitor, C1, must be connected from close to this pin to GND.

SW. Low-side switch connection between the inductor, L1, and ground. Because rapid changes of current occur at this pin, the traces on the PCB that are connected to this pin should

be minimized. In addition, L1 and the diode D1 should be connected as close to this pin as possible.

OVP. Overvoltage Protection sense pin to protect the A8431 from excessive voltage on the SW pin. This pin should be connected to the output capacitor, C2. To disable this feature connect the pin to ground.

EN. Setting lower than 0.4 V disables the A8431 and puts the control circuit into the low-power Sleep mode. Greater than 1.5 V fully enables the A8431.

GND. Ground reference connected directly to the ground plane. The sense resistor, R1, should have a separate connection directly to this point.

FB. Feedback pin for LED current control. The reference voltage is 95 mV. The top of R1 is typically connected here.

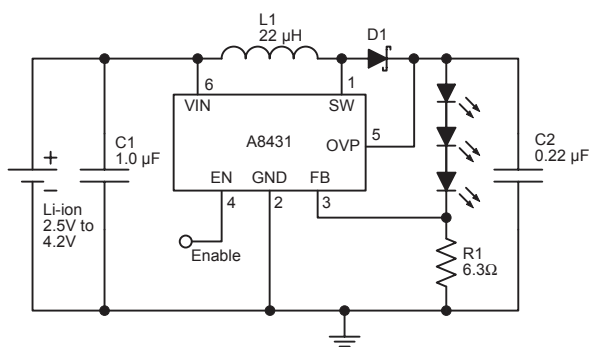

Schematic 1. Typical application

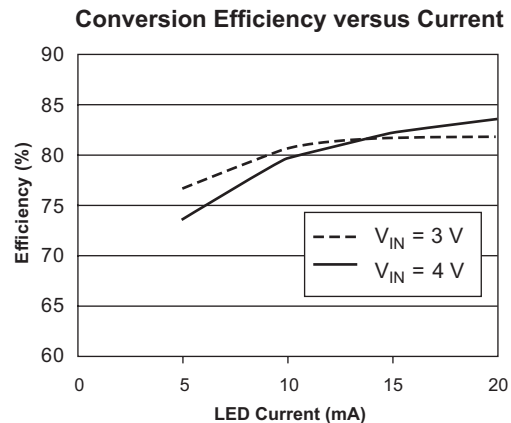

Chart 1. Conversion efficiency when driving three LEDs in the typical application circuit.

Device Operation

The A8431 uses a constant-frequency, current-mode control scheme to regulate the current through the load. The load current produces a voltage across the external sense resistor (R1 in schematic 1) and the input at the FB pin. This voltage is then compared to the internal 95 mV reference to produce an error signal. The switch current is sensed by the internal sense resistor and compared to the load current error signal. As the load current increases, the error signal diminishes, reducing the maximum switch current and thus the current delivered to the load. As the load current decreases, the error signal rises, increasing the maximum switch current and thus increasing the current delivered to the load.

To set the load current, ensure that the required internal reference value of 95 mV is produced at the desired load. To do so, select a resistance value for the sense resistor, R1 (Ω), such that:

$$R1 = 95 \text{ mV} / I_{\text{LOAD}}$$

where I_{LOAD} is the target load current (mA).

The table below shows typical values for R1. Note that the resistance value is from the standard E96 series.

As load current is reduced, the energy required in the inductor, L1, diminishes, resulting in the inductor current dropping to 0 A for low load-current levels. This is known

as Discontinuous mode operation, and results in some low-frequency ripple. The average load current, however, remains regulated down to 0 A.

In Discontinuous mode, when the inductor current drops to 0 A, the voltage at the SW pin rings, due to the capacitance in the resonant LC circuit formed by the inductor and the capacitance of the switch and the diode. This ringing is low-frequency and is not harmful. It can be damped with a resistor across the inductor, but this reduces efficiency and is not recommended.

Overvoltage Protection

An overvoltage event can occur when the LEDs become disconnected or fail in an open state. In these cases, the current flow through the sense resistor, R1, becomes 0 A and thus the feedback voltage, V_{FB} becomes 0 V. The A8431 compensates by increasing the on time of the switch, which increases the output voltage.

The A8431 has built-in protection to guard against excessive voltage on the SW pin. If the output voltage exceeds the typical level of the Output Overvoltage Rising Limit, V_{OVPR} , then the overvoltage protection circuitry shuts off the internal switch until the output voltage falls below the Output Overvoltage Falling Limit, V_{OVPF} . At this point, the A8431 operates normally. There is no need for an external Zener diode for the A8431.

Power Dissipation versus I_{OUT}

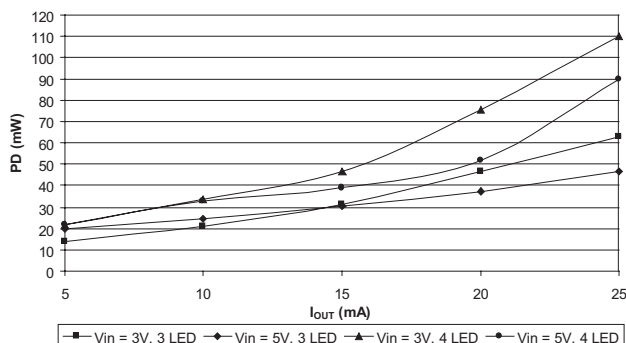

Target Load Current (I_{LOAD}) (mA)	Sense Resistor (R1) (Ω)
5	19.1
10	9.53
12	7.87
15	6.34
20	4.75

Application Information

Component Selection

The component values shown in schematic 1 are sufficient for most applications. To reduce the output ripple, L1 may be increased, but in most cases this results in excessive board area and cost.

Inductor Selection. With an internal PWM frequency of 1.2 MHz, the optimal L1 value for most cases is 22 μH . For worst case conditions (high output voltage and current and low input voltage), the inductor should be rated at the switch current limit, I_{SWLIM} . If high temperature operation is required, a derating factor will have to be considered. In some cases, where lower inductor currents are expected, the current rating can be decreased. Several inductor manufacturers, including: Coilcraft, Murata, Panasonic, Sumida, Taiyo Yuden, and TDK, have and are developing suitable small-size inductors.

Diode Selection. The diode should have a low forward voltage to reduce conduction losses. In addition, it should have a low capacitance to reduce switching losses. Schottky diodes can provide both these features, if carefully selected. The forward voltage drop is a natural advantage for Schottky diodes, and it reduces as the current rating increases. However, as the current rating increases, the diode capacitance also increases. As a result, the optimal selection is usually the lowest current rating above the circuit maximum. In this application, a current rating in the range from 100 mA to 200 mA is usually sufficient.

Capacitor Selection. Because the capacitor values are low, ceramic capacitors are the best choice for this application. To reduce performance variation as temperature changes, low-drift capacitor types, such as X7R and X5R, should be used. A 1.0 μF capacitor on the VIN pin is suitable for most applications. In cases where large inductor currents are switched, a larger capacitor may be needed. The output capacitor, C2, can be as small as 0.22 μF for most applications and most input/output voltage ranges. Increasing the capacitor value on the output aids in increasing the efficiency of low input voltage/high output voltage

conditions. Suitable capacitors are available from TDK, Taiyo Yuden, Murata, Kemet, and AVX.

Dimming Control

LED brightness can be controlled either: (a) by modifying the voltage at the top of R1 to control the LED current, I_{LOAD} , directly, or (b) by using a PWM signal on the EN pin to chop the output.

Feedback Modulation. By adding a voltage drop between the FB pin and R1, as shown in schematic 2, the LED current, I_{LOAD} , can be made to decrease. As V_{C} (control voltage) increases, the voltage drop across R2 also increases. This causes the voltage at FB to increase, and the A8431 reduces I_{LOAD} to compensate. As V_{C} increases further, the current drops to 0 A, and R2 maintains the full 95 mV on FB. Reducing V_{C} diminishes the voltage across R2 until, when V_{C} is at 95 mV, there is no drop across R2 and the current level is defined by R1. Reducing V_{C} below 95 mV causes I_{LOAD} to increase further, due to the voltage drop across R2 in the reverse direction. This continues until, when V_{C} is at 0 V, there is approximately 5 mV across R2. At that point, I_{LOAD} (mA), is defined as:

$$I_{\text{LOAD}} = 100 \text{ mV} / R1$$

where R1 is the resistance of the sense resistor (Ω).

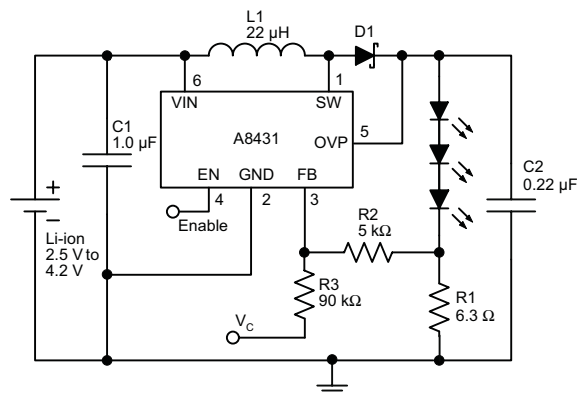

Schematic 2. Dimming control with dc voltage

PWM Control. The control voltage, V_C , also can be generated by a filtered PWM signal, as shown in schematic 3. In this case, a 0% duty cycle (PWM=0 V) corresponds to full brightness and a 100% duty cycle causes the LED current, I_{LOAD} , to go to 0 A.

By applying a PWM signal directly to the EN pin, the A8431 is turned on or off, and I_{LOAD} is either full (as defined by R1) or 0 A. By varying the duty cycle of the PWM signal, the LED brightness can be controlled from off (0% duty cycle) to full (100% duty cycle). The PWM frequency should be in the range from 1 kHz to 10 kHz.

Several other schemes are possible, for example, digitally switching additional resistors across R1 to increase I_{LOAD} . In this case, R1 would be selected for the minimum desired brightness.

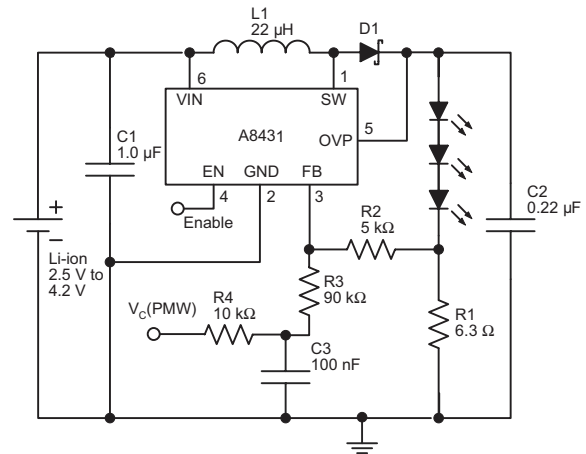

Schematic 3. Dimming control with filtered PWM

Start-Up

To provide fast start-up operation, no soft start is implemented in the control circuit. At power-on, the bypass capacitor, C1, is discharged, which means that the supply must provide the in-rush current through the inductor, L1.

This can be reduced by modulating the feedback with a soft-start circuit as shown in schematic 4. When power is first applied, the capacitor C3 is discharged and pulls the FB pin high, reducing the output drive to minimum. As C3 charges, when the bottom drops below about 0.8 V, the feedback from the sense resistor, R1, takes over full control of the output current.

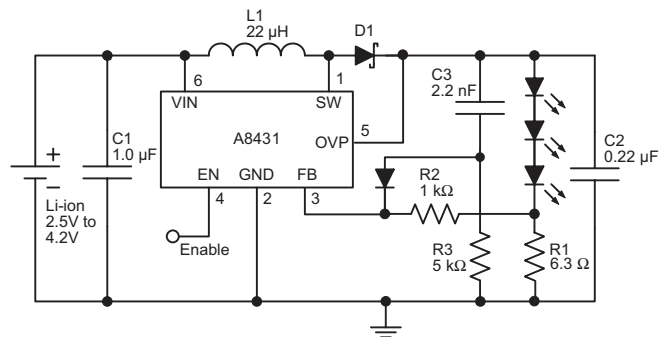

Schematic 4. Soft start operation

Parallel LED Strings

The A8431 can be used to power parallel strings of LEDs, which have the same number of LEDs on each string. It is important that the voltage drop is the same across all of the parallel strings, to ensure that all of the LEDs are illuminated and that the current through each string is equal.

A typical circuit with two parallel strings is shown in schematic 5. The conversion efficiency of this configuration is shown in chart 2.

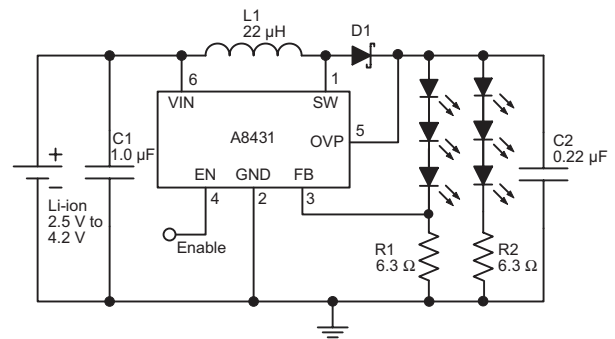

Schematic 5. Parallel strings of LEDs

Conversion Efficiency for Two Parallel Strings

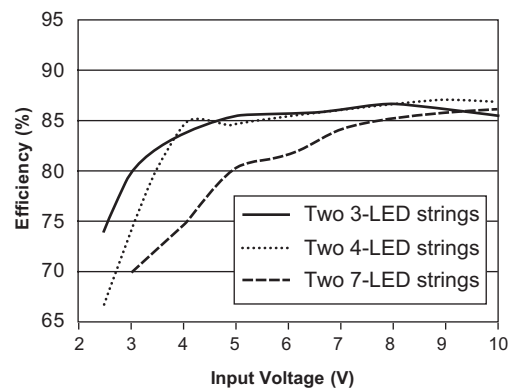
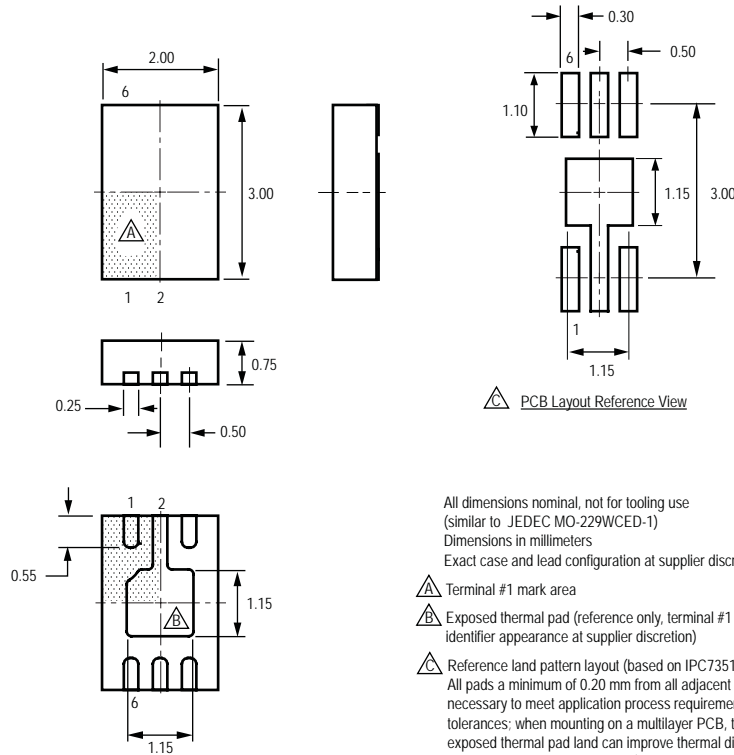

Chart 2. Conversion efficiency when driving two parallel strings of varying lengths

Package EH, 6-pin MLP/DFN



All dimensions nominal, not for tooling use
(similar to JEDEC MO-229WCED-1)
Dimensions in millimeters
Exact case and lead configuration at supplier discretion within limits shown

- △ Terminal #1 mark area
- △ Exposed thermal pad (reference only, terminal #1 identifier appearance at supplier discretion)
- △ Reference land pattern layout (based on IPC7351)
All pads a minimum of 0.20 mm from all adjacent pads; adjust as necessary to meet application process requirements and PCB layout tolerances; when mounting on a multilayer PCB, thermal vias at the exposed thermal pad land can improve thermal dissipation (reference EIA/JEDEC Standard JESD51-5)

Copyright ©2003, 2007, Allegro MicroSystems, Inc.

The products described here are manufactured under one or more U.S. patents or U.S. patents pending.

Allegro MicroSystems, Inc. reserves the right to make, from time to time, such departures from the detail specifications as may be required to permit improvements in the performance, reliability, or manufacturability of its products. Before placing an order, the user is cautioned to verify that the information being relied upon is current.

Allegro's products are not to be used in life support devices or systems, if a failure of an Allegro product can reasonably be expected to cause the failure of that life support device or system, or to affect the safety or effectiveness of that device or system.

The information included herein is believed to be accurate and reliable. However, Allegro MicroSystems, Inc. assumes no responsibility for its use; nor for any infringement of patents or other rights of third parties which may result from its use.

For the latest version of this document, visit our website:

www.allegromicro.com